

INSTRUKCJA MONTAŻU

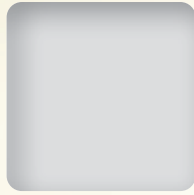

01 linia MEDIUM 56

4 - 8

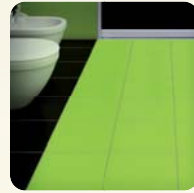
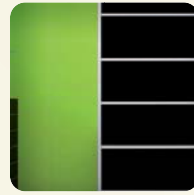

02 linia PREMIUM 75

9 - 26



03 linia TYTAN

27 - 34



04 linia CYKLOP

35 - 39



05 Inne

40 - 46



50 kg

linia:

Premium 75



tor SOLO

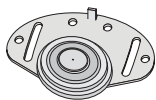

Wózek dolny Solo



Wkręt Solo

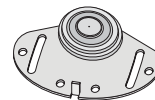

Wózek górny Solo

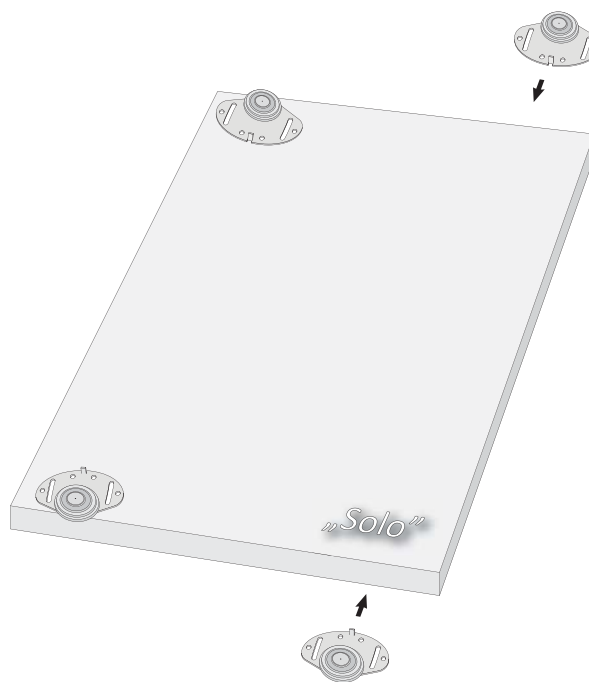

	2 szt. drzwi	Z=30
	3 szt. drzwi	Z=60
	4 szt. drzwi	Z=60
	4 szt. drzwi	Z=90

Zakładki

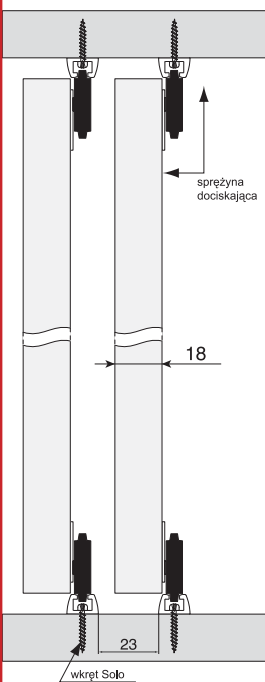

Aby obliczyć wysokość płyty:

$$\dots - 16 \text{ mm} = \dots$$

wysokość światła otworu wysokość płyty

* wysokość formatki razem z okleiną.

Aby obliczyć szerokość płyty:

$$(\dots + \dots) : \dots = \dots$$

szerokość światła otworu zakładka ilość drzwi szerokość płyty

* wysokość formatki razem z okleiną.

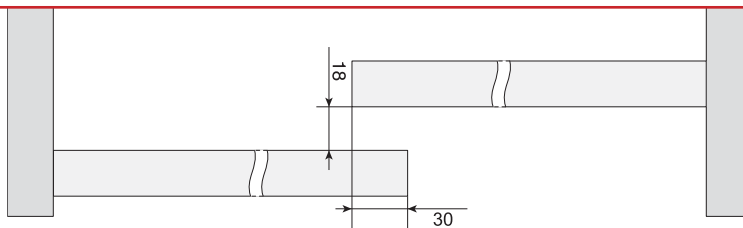

2

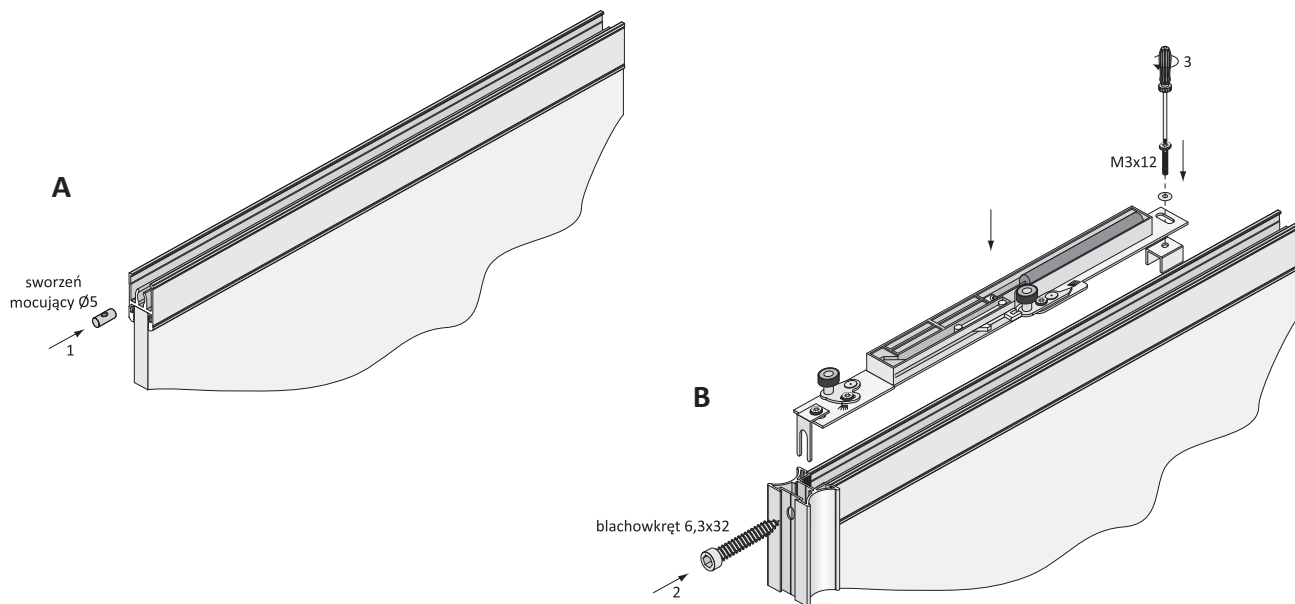

W zależności od użytej rączki przeprowadzić regulację 4, następnie dokręcić wkręt 5

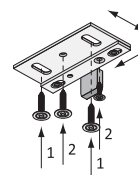
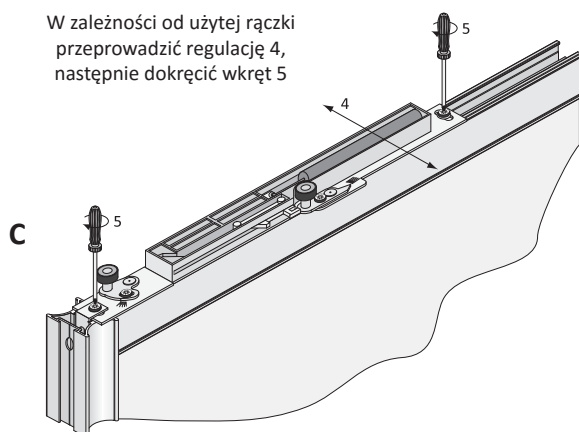

Przykręcić zacpek wkrętami 1, wyregulować (regulacja w dwóch płaszczyznach), a następnie zablokować wkrętami 2.

Wymiar X jest zmienny i zależy od rodzaju zastosowanej rączki:

- Westa KR 18/P - 11 mm
- Juno KR 18/P - 11 mm
- Uran 10/P - 13 mm
- Merkury 10/P - 11 mm
- Syriusz 10/P - 11 mm

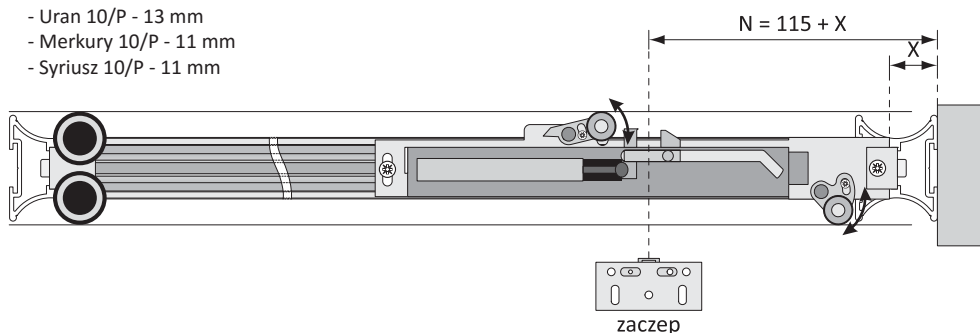

Zakres proporcji wymiarów oraz ciężaru drzwi, do których jest możliwość zamontowania samodomykacza.

Dla drzwi z wózkiem WD Matrix 10:

Stosunek h/d	Dopuszczalna waga drzwi
1/1	16 - 35 kg
2/1	19 - 35 kg
3/1	26 - 35 kg
4/1	30 - 35 kg
5/1	nie zalecane

h - wysokość drzwi
d - szerokość drzwi

Przybliżona masa 1m² wybranych wypełnień drzwi:

- płyta wiórowa 18 mm - 14 kg
- płyta wiórowa 10 mm - 8 kg
- szkło 4 mm - 11 kg

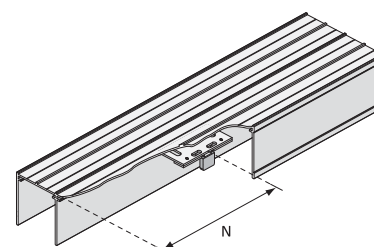
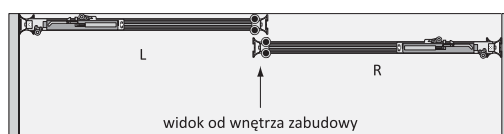



16 mm

18 mm

Samodomykacz

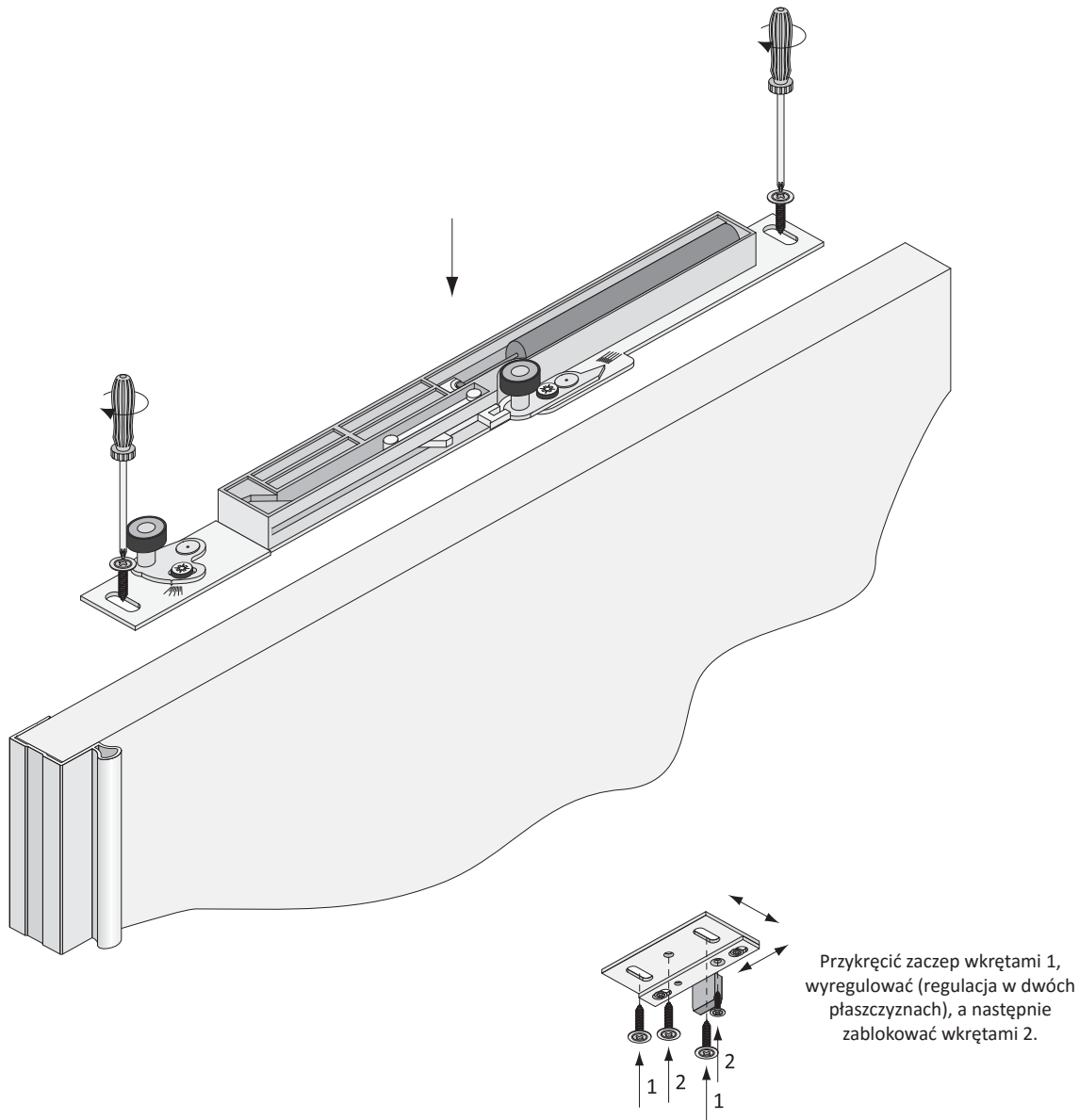

Zakres proporcji wymiarów oraz ciężaru drzwi, do których jest możliwość zamontowania samodomykacza.

Dla drzwi z wózkiem WD Lexus 18:

Stosunek h/d	Dopuszczalna waga drzwi
1/1	16 - 35 kg
2/1	19 - 35 kg
3/1	26 - 35 kg
4/1	30 - 35 kg
5/1	nie zalecane

h - wysokość drzwi
d - szerokość drzwi

Przybliżona masa 1m² wybranych wypełnień drzwi:

- płyta wiórowa 18 mm - 14 kg
- płyta wiórowa 12 mm - 9 kg
- szkło 4 mm - 11 kg

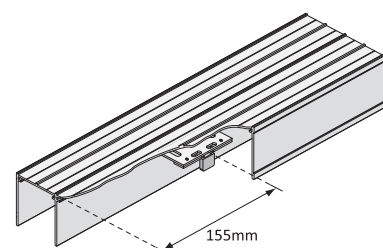
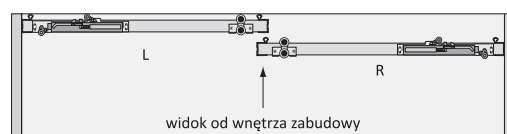
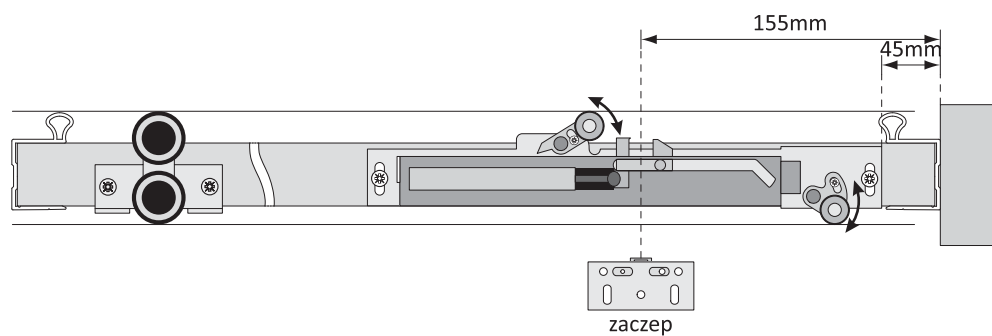

Samodomykacz MPX-25, MPX-40



10 mm

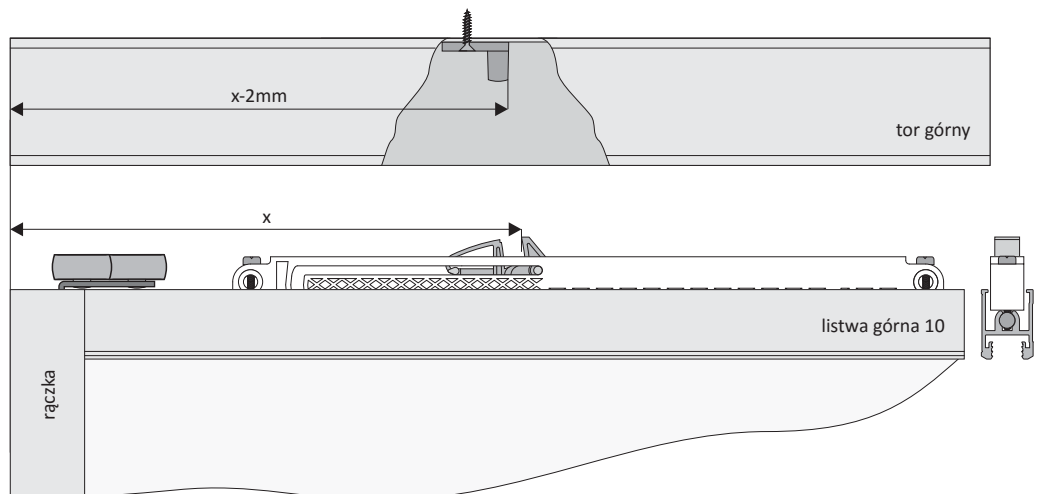
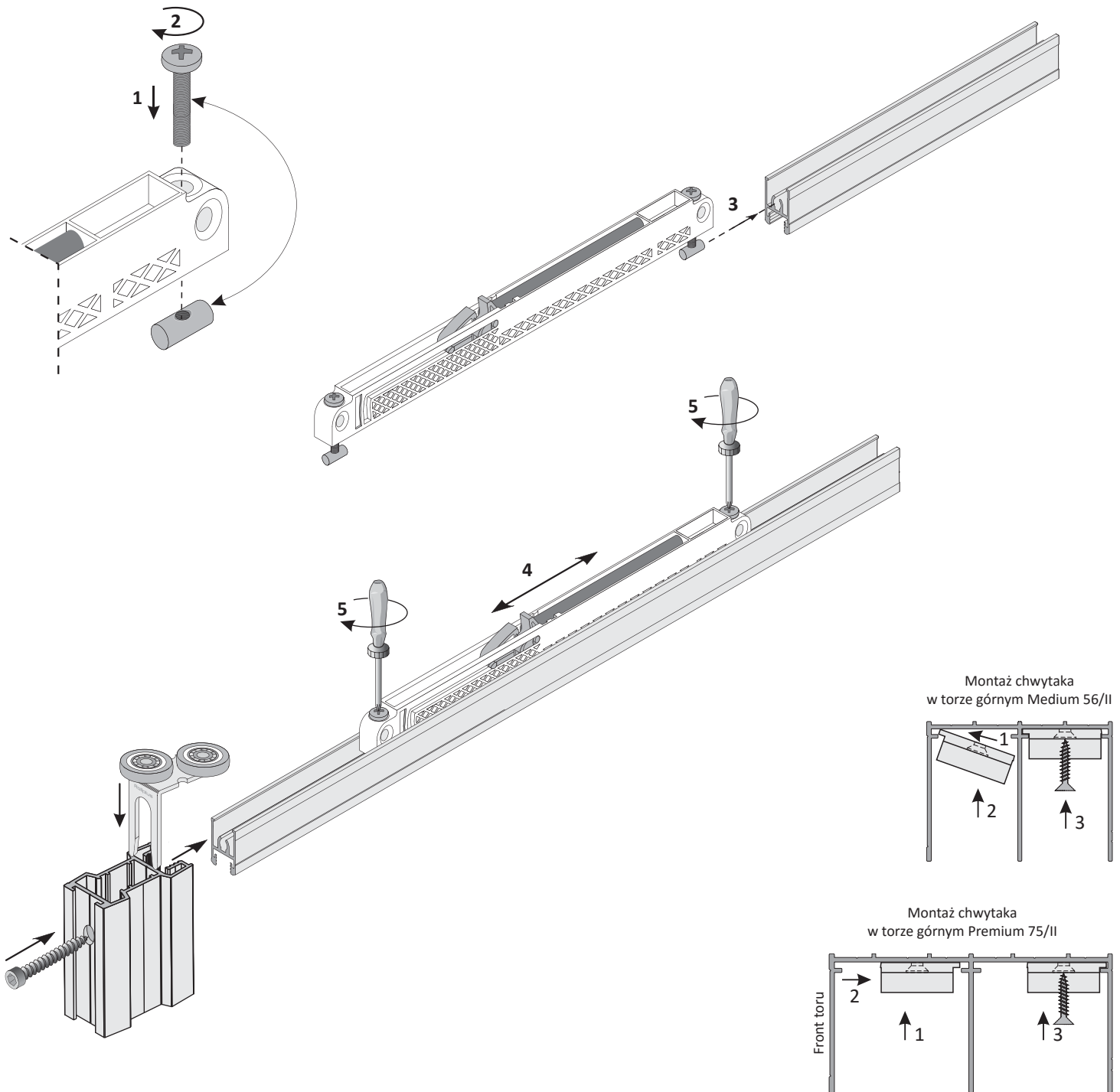

Do zestawu dołączone są trzy chwytaki o różnych wysokościach. Po wyregulowaniu drzwi, dobrać odpowiedni chwytak.

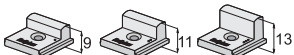

Przy zastosowaniu samodomykacza nie używać stopera toru górnego.



Szablon 10

Przyrząd do wiercenia otworów montażowych w rączkach:

- Afrodyta 10/M
- Zeus 10/M
- Uranos 10/M
- Kronos 10/M
- Syriusz 10/P
- Merkury 10/P
- Uran 10/P

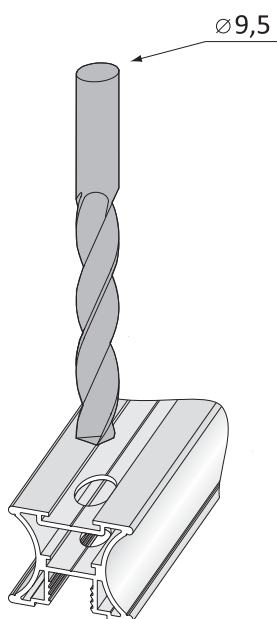
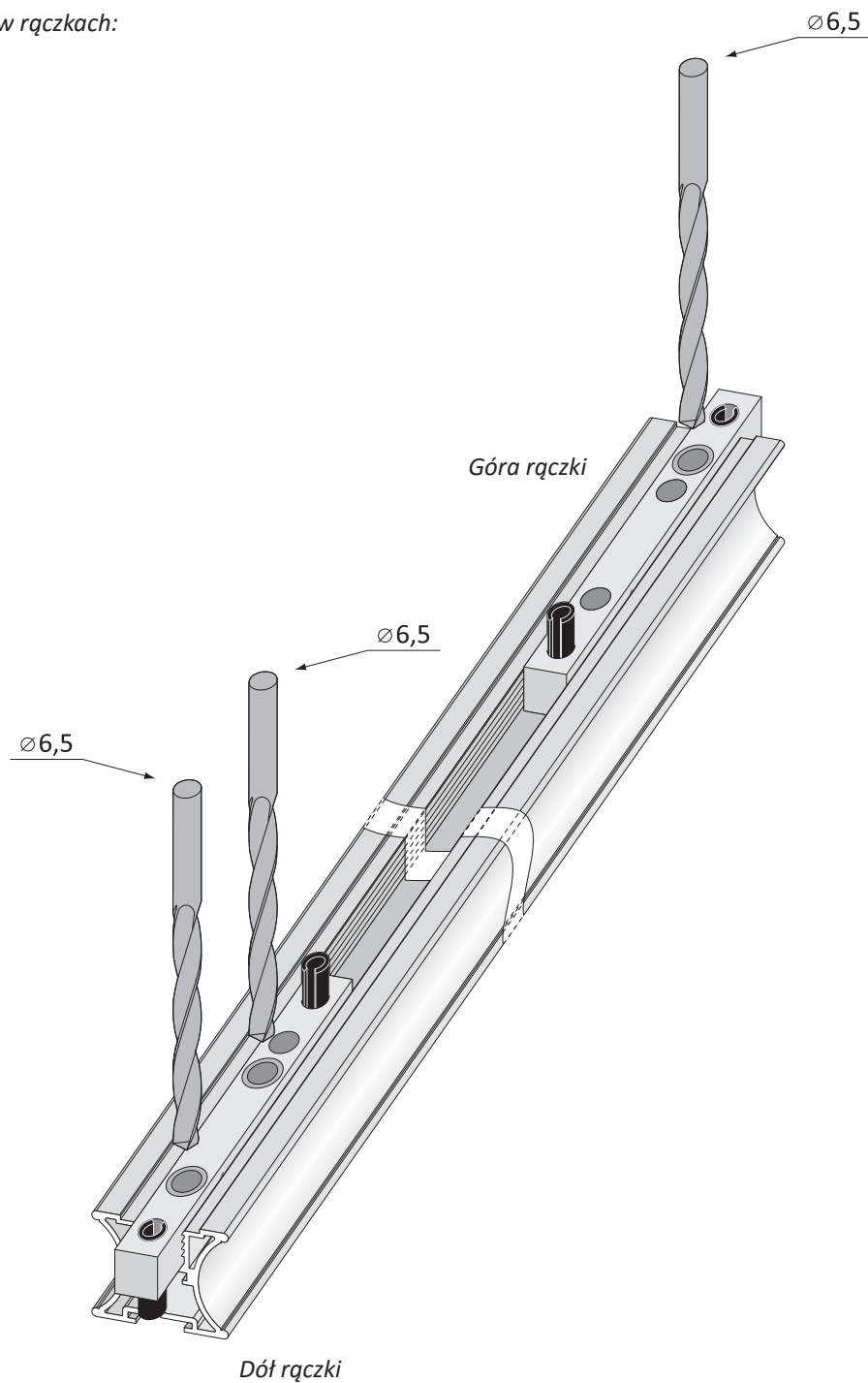
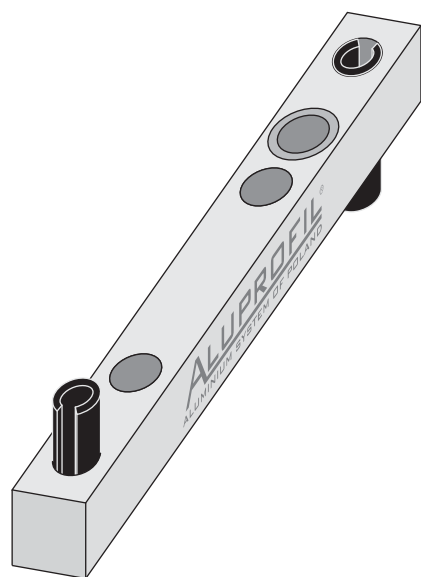

Po wywierceniu otworu $\varnothing 6,5$, otwory w zewnętrznej ścianie rączki rozwiercamy wiertłem $\varnothing 9,5$.

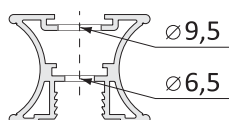

Łączniki

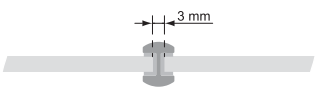
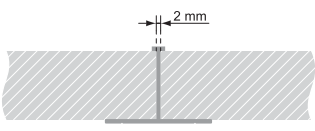
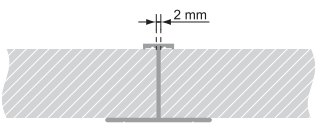
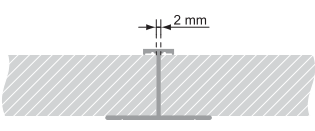
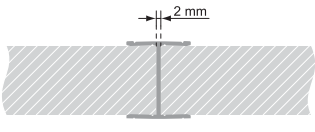
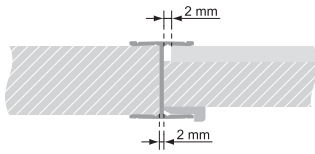
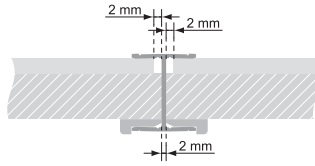
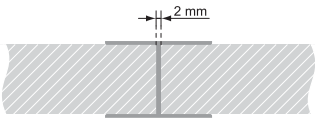
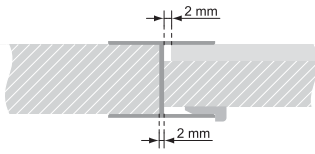
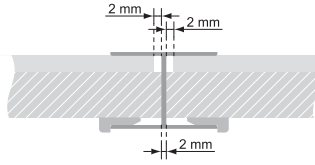
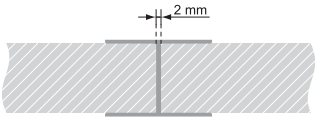
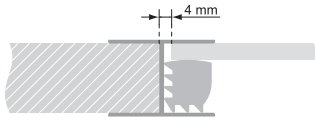
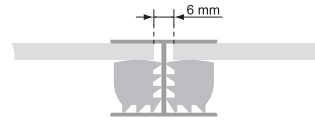
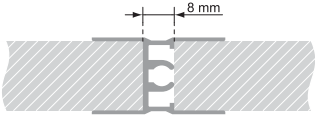
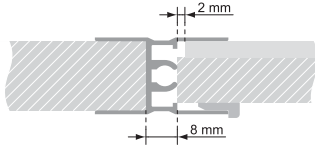
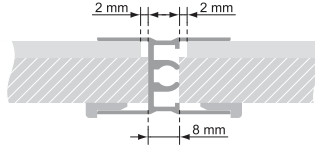
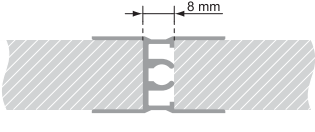
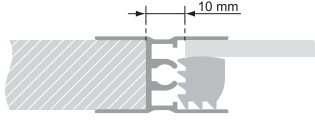
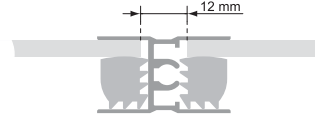
	Łączenie płyta / płyta	Łączenie płyta / szkło	Łączenie szkło / szkło
Łącznik H-6/4		-	-
Łącznik H-4/18		-	-
Łącznik H-8/16		-	-
Łącznik H-8/18		-	-
Łącznik H-17/18			
Łącznik H-28/18 (konstrukcja standardowa)			
Łącznik H-28/18 (konstrukcja ramowa)			
Łącznik H-35/18 (konstrukcja standardowa)			
Łącznik H-35/18 (konstrukcja ramowa)			

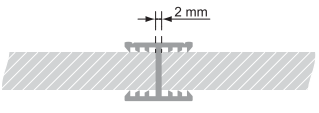
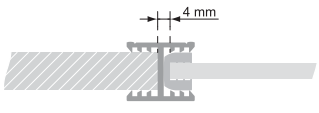
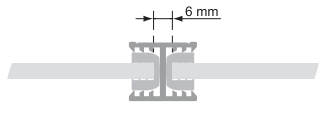
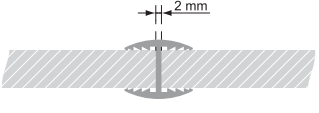
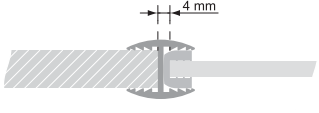
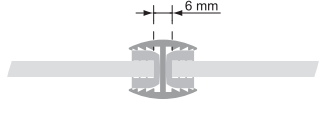
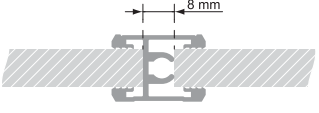
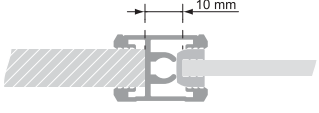
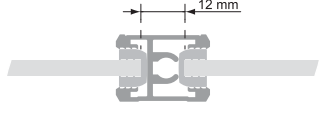
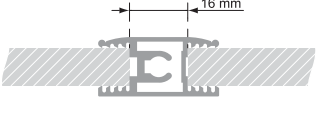
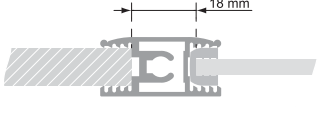
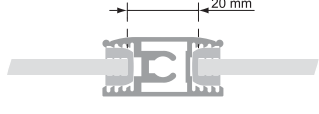
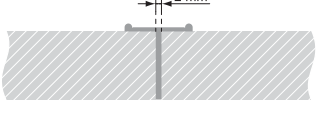
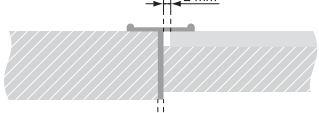
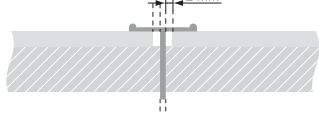
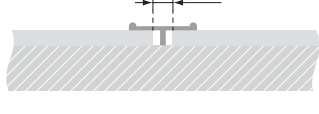
	łączenie płyta / płyta	łączenie płyta / szkło	łączenie szkło / szkło
Łącznik H-17/10			
Łącznik H-18/10			
Łącznik H-25/10			
Łącznik H-30/10			
Teownik T-16			
Teownik T-4	-	-	

Elementy dodatkowe

	Classic Plus 18/M	Afrodyta 10/M	Zeus 10/M	Uranos 10/M	Kronos 10/M	Orion 18/P	Eris 18/P	Classic 18/P	Wenus Eko 18/P	Pluton 18/P	Wega 18/P	Westa BIS 18/P	Jowisz 18/P	Wenus 18/P	Neptun 18/P	Westa 18/P	Juno 18/P	Syriusz 10/P	Mercury 10/P	Uran 10/P	
Łącznik H-17/18						✓	✓	✓	✓	✓	✓	✓	✓	✓	✓	✓	✓				
Łącznik H-28/18						✓	✓	✓	✓	✓	✓	✓	✓	✓	✓	✓	✓				
Łącznik H-35/18																✓	✓				
Łącznik H-17/10		✓	✓	✓	✓														✓	✓	✓
Łącznik H-25/10		✓	✓	✓	✓														✓	✓	✓
Teownik T-16						✓	✓	✓	✓	✓	✓	✓	✓	✓	✓	✓	✓				
Teownik T-4						✓	✓	✓	✓	✓	✓	✓	✓	✓	✓	✓	✓				
Folia drewnopodobna		✓	✓	✓	✓						✓		✓	✓	✓				✓	✓	✓
Samodomykacz						✓	✓	✓	✓	✓	✓	✓	✓	✓	✓	✓	✓	✓	✓	✓	✓
Uszczelka 10-S 4; 4,5; 6; 8 mm		✓	✓	✓	✓														✓	✓	✓
Klin mocujący do szkła																✓	✓				
Tor dolny pojedynczy N	✓	✓	✓	✓	✓	✓	✓	✓	✓	✓	✓	✓	✓	✓	✓	✓	✓	✓	✓	✓	✓
Tor górny Medium 29/l	✓	✓	✓	✓	✓																
Tor górny Premium 38/l						✓	✓	✓	✓	✓	✓	✓	✓	✓	✓	✓	✓	✓	✓	✓	✓
Szczotka odbojowa bez kleju 4,8 x 4														✓	✓						
Szczotka odbojowa bez kleju 14,5 x 4	✓	✓	✓	✓	✓							✓				✓	✓	✓	✓	✓	✓
Szczotka odbojowa z klejem 4,8 x 4						✓	✓	✓	✓	✓	✓		✓								
Szczotka przeciwkurzowa bez kleju 4,8 x 13																✓	✓	✓	✓		
Szczotka przeciwkurzowa bez kleju 4,8 x 8		✓	✓	✓	✓																
Szczotka przeciwkurzowa z klejem 6,7 x 13						✓	✓	✓	✓	✓	✓	✓	✓	✓							
Szczotka przeciwkurzowa z klejem 6,9 x 6	✓																				
Taśma dwustronna										✓	✓	✓	✓	✓	✓						
Folia zabezpieczająca do lustra		✓	✓	✓	✓											✓	✓	✓	✓	✓	✓
Zamek do drzwi przesuwnych						✓	✓	✓	✓	✓	✓	✓	✓	✓	✓	✓	✓				
Zapinka do szczotki						✓	✓	✓	✓	✓	✓		✓								

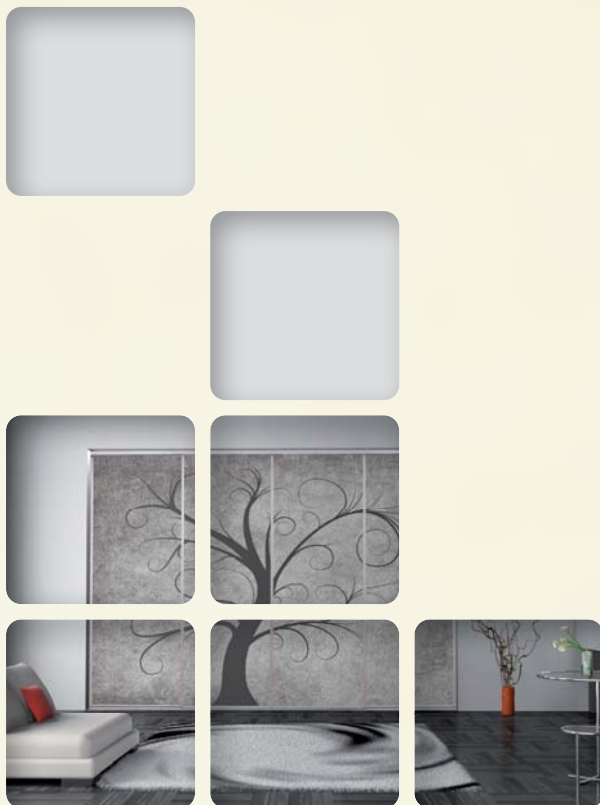

ALUPROFIL sp. z o.o.
Plac Czerwca 1976 roku nr 7
02-495 Warszawa

tel.: +48 22 478 33 03
fax: +48 22 478 33 02
e-mail: biuro@aluprofil.pl

Instrukcja montażu - wersja ALU-24e
www.aluprofil.pl